

Swivel

30KG, 40KG, 50KG, 60KG

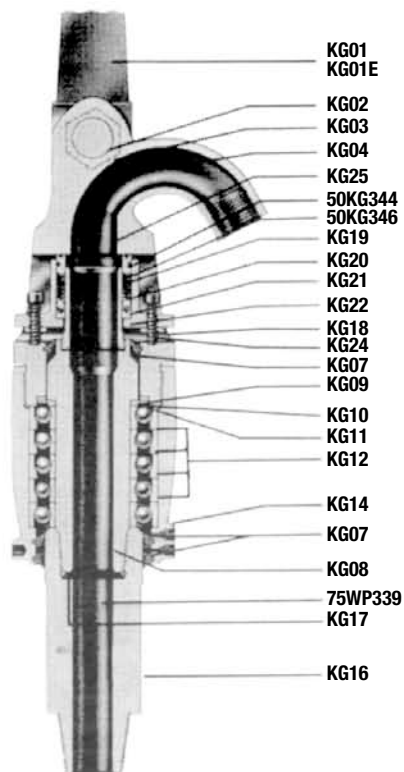

For drilling relatively shallow oil wells, the deepest water wells, workover rigs, slim hole drilling and “drilling in” and coring oil wells by the reverse circulation method.

King 30, 40, 50, and 60KG Swivels provide the same oversize watercourse as the King XV series, and also feature a washpipe with adjustable Chevron V-Type packing.

They are streamlined and compactly constructed. They are made of high-grade alloy steel and have great capacities, proportionate to their weights.

The bearings are angular-contact type ball bearings. Weight of the drill pipe (downthrust) is carried on quadruplex units. The (4) four bearings in this unit are flush ground, on their faces and matched so that each bearing will support its share of the load.*

Reverse loads (upthrusts) are absorbed by a single bearing that is mounted opposed to the quadruplex unit. The type of bearings used and the manner in which they are mounted provide ample radial capacity to stabilize the swivels.

The packing unit consists of a stuffing box and Chevron V-Type packing.

These swivels can be repacked, within a few minutes, without “breaking out” any connection. The entire packing assembly can be replaced in 10 minutes or less. It is not necessary to remove any other part of the swivel to repack. This eliminates the possibility of thread-galling.

Because of the large oversize watercourse and packing arrangement, these swivels are ideally suited for both conventional and reverse circulation methods.

Features in Brief

- Oversize watercourses permit circulation of more drilling fluids.
- Multiple ball bearing units provide ample thrust and radial capacities.*
- Sealed housing protects the bearings and retains lubricant.
- Grease lubrication of the bearings is accomplished through a readily accessible fitting.
- Choice of conventional bail or elevator shank.
- Zerk fitting in stuffing box simplifies lubrication and greatly prolongs life of Chevron V-Type packing.
- Packing components and assemblies are interchangeable in types 30, 40, 50 and 60KG Swivels.

These swivels are furnished with a conventional bail or a plain elevator shank, at the option of the purchaser. Shanks, for use with more than one size elevator, will be furnished to order at an extra cost. Shanks can be furnished for use in connection with “bottleneck” elevators.

Kelly connection on the 30KG Swivel is 4 1/2”, 8-V, left-hand thread, 3/4” TPF drill pipe. This accommodates a 3” watercourse through the swivel.

Kelly connection on the 40KG Swivel is 3 1/2” API specification, full hole pin, left hand thread. If a three-inch watercourse is required, through the swivel, a 4 1/2” left hand thread, drill pipe thread will be substituted for the tool joint pin at no extra charge.

Kelly connection on the 50KG and 60KG Swivels is 4 1/2” API, regular tool joint pin, left hand thread. If 3” watercourse is required, a 6 5/8” regular, left hand pin, will be furnished at extra cost.

When a swivel is purchased, an extra set of packing and a hardened and ground washpipe should be purchased. The swivel should never be in operation without these extra parts on hand.

These swivels are designed to operate efficiently at relatively high rotating speeds.

*The 60KG Swivel features tapered bearings.

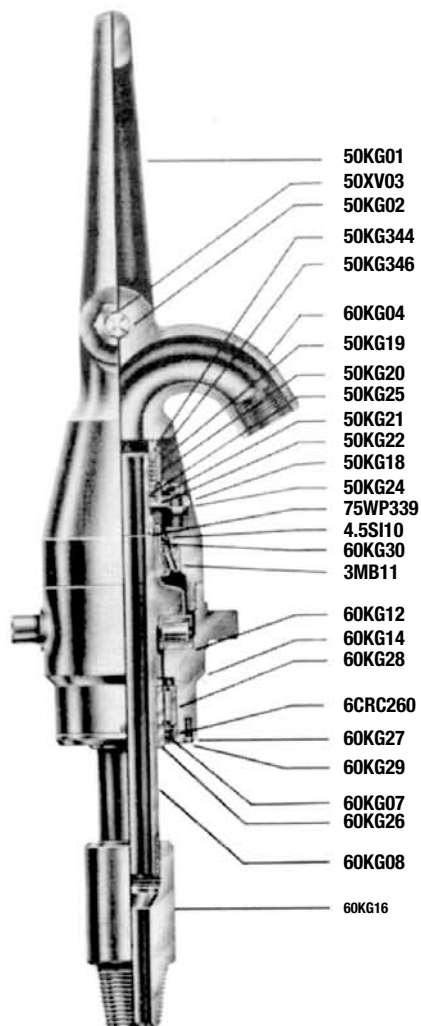

30KG, 40KG, 50KG, 60KG

Capacity and Safety Data*

Type Swivel	Capacity, lbs. at 100 R.P.M.	Static Load Limit, lbs.	Safe Depths (Feet) with Drill Pipe			
			2 3/8" 6.65 lbs.	2 7/8" 10.4 lbs.	3 1/2" 13.3 lbs.	4 1/2" 16.6 lbs.
30KG	44,000*	95,000	6,400	4,000	3,400	2,600
40KG	54,000*	140,000	8,000	5,000	3,800	3,000
50KG	65,000	160,000	10,000	6,200	4,800	3,805
60KG	88,000	160,000				

(API Rating)

*Non oilfield rating.

Swivel Type	Lower (Kelly) Connection	Weight lbs.*	Length Overall	Working Length	Hose Conn.	Diameter Watercourse	Bail Opening
30KG	4 1/2" D.8-V, L.H., 3/4" TPF	225	45"	37"	3" NPT	3"	5" x 8" or 6" x 14"
40KG	3 1/2" API F.H. Pin, LH	347	57"	50"	3" NPT	2 1/2"	6" x 14"
40KG	4 1/2" D.8-V, L.H., 3/4" TPF	347	57"	50"	3" NPT	3"	6" x 14"
50KG	4 1/2" API Reg. Pin, LH	512	63"	55"	3" NPT	2 1/2"	7" x 16"
50KG	6 5/8" API Reg. Pin, LH	593	67"	59"	3" NPT	3"	7" x 16"
60KG	6 5/8" API Reg. Pin, LH	625	71"	59"	3" NPT	3"	7" x 16"

Parts List for Type KG King Swivels

Name of Part	Number Required	30KG			40KG			50KG		
		Part Number	Net Weight lbs.	Spares for One Year Service	Part Number	Net Weight lbs.	Spares for One Year	Part Number	Net Weight lbs.	Spares for One Year Service
Bail	1	N30KG01	26	...	N40KG01	52	...	N50KG01	74	...
Bail (6" x 14")	1	N32GA10	32	30
Elevator Shank	1	N30KG01E	48	...	N30KG01E*	62	...	N50KG01E	73	...
Bail Gudgeon Pin	1	N32GA11	6 1/4	...	N40KG02	11 3/4	...	N50KG02	14 1/2	...
Bail Pin Nuts	2	N32GA11 A	2 (2)	...	N50KG02A	3 (2)	...	N50KG02A	3 (2)	...
Gooseneck	1	N30KG04	64	...	N40KG04	87	...	N50KG04	129	...
Housing Seals	1	N30XV07	1/2	2	N4S07	1/2 (3)	3	N30XV07	1/4	1
Housing Seals	2	N50KG07	3/4 (2)	2
Bearing Spindle	1	N50KG08	18	...	N40KG08	23 1/2	...	N50KG08	39	...
Shield Seal	1	N30XV09	1/2	1	N30XV09	1/2	1	N50XV09	1/16	1
Bearing Shield	1	N30XV10	3/4	...	N30XV10	3/4	...	N50KG10	7/8	...
Bearing Retainer Wire	1	N30XV11	1/16	...	N30XV 11	1/16	...	N50KG11	1/8	...
Bearing	1 set	N30XV12	26 (4)	1 set	N30XV12	34 (5)	1 set	N50KG12	46 (5)	1 set
Bearing Housing	1	N30KG14	40	...	N40KG14	63	...	N50KG14A	85	...
Housing Lock Bolt	1	N50XV15	1/4	1/4	...	N50XV15	1/4	...
Spindle Thread Seal	1	N50KG17	1/8	...	N50KG17	1/8	...	N50KG17	1/8	...
O-Ring	1	N75WP339	1/8	2	N75WP339	1/8	2	N75WP339	1/8	2
O-Ring	1	N50KG344	1/8	2	N50KG344	1/8	2	N50KG344	1/8	2
O-Ring	1	N50KG346	1/8	2	N50KG346	1/8	2	N50KG346	1/8	2
Stuffing Box	1	N50KG18	12 1/4	1	N50KG18	1/8	1	N50KG18	12 1/4	1
Packing Gland	1	N50KG19	2	1	N50KG19	12 1/4	1	N50KG19	2	1
Packing	1 set	N50KG20	1/2	6 sets	N50KG20	1/2	6 sets	N50KG20	1/2	6 sets
Lantern Ring	1	N50KG21	1	1	N50KG21	1	1	N50KG21	1	1
Packet Seat Ring	1	N50KG22	1/2	1	N50KG22	1/2	1	N50KG22	1/2	1
Adjusting Lock Nut	2	N50KG23	1/4	...	N50KG23	1/4	...	N50KG23	1/4	...
Adjusting Screw	2	N50KG24	1/2	...	N50KG24	1/2	...	N50KG24	1/2	...
Washpipe	1	N50KG25	4 1/2	3	N50KG25	4 1/2	3	N50KG25	4 1/2	3

* 50KG requires one 30XV07 upper housing seal and two 50XV07 lower housing seals. ** Downthrust bearings should always be replaced with full matched sets.

Parts List for 60KG King Swivel

Part Number	Name of Part	Number Required	Net Weight lbs.	Spares for One Year Service	Part Number	Name of Part	Number Required	Net Weight lbs.	Spares for One Year Service
N50KG01A	Bail	1	75	-	N50KG20	Packing Set	1	1/2	6
N50KG02	Bail Pin	1	15	-	N50KG21	Lantern Ring	1	1	1
N50KG03	Bail Pin Nut	2	2 (2)	-	N50KG22	Packing Seat Ring	1	1/2	1
N60KG04	Gooseneck	1	130	-	N50KG24	Adjusting Screw w/Nuts	2	1 1/2 (2)	-
N60KG07	Housing Seal	1	1/4	1	N50KG25	Washpipe	1	4 1/2	3
N60KG08	Spindle	1	85	-	N60KG26	Lower Wear Sleeve	1	2 1/2	-
N4.5SI10	Housing Seal	1	1/4	1	N60KG27	Lower Oil Box	1	6	-
N3MB11	Upper Bearing	1	12	1	N60KG28	Lower Bearing	1	12	-
N60KG12	Main Bearing	1	25	1	N60KG29	Cap Screws	6	1 (6)	-
N60KG14	Bearing Housing	1	85	-	N60KG30	Upper Wear Ring	1	2	-
N60KG16	Lower Connection	1	76	-	N6CRC260	O-Ring (Oil Box)	1	1/4	1
N50KG18	Stuffing Box	1	12 1/4	1	N75WP339	O-Ring (Washpipe)	1	1/4	3
N50KG19	Packing Gland	1	2	1	N50KG344	O-Ring (Pkg. Gland)	1	1/4	2
					N50KG346	O-Ring (Pkg. Gland)	1	1/4	2