

Side-Inlet Swivel

4.5SI

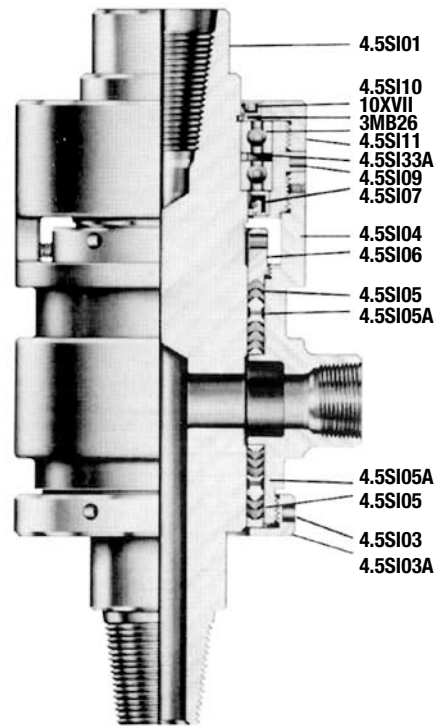

These swivels are manufactured and designed to fill a need when conventional swivels are not practical or applicable. Side inlet swivels find a wide application when using hydraulic, top-head drive rigs. Mounted below the hydraulic assembly, they prevent contamination of hydraulic fluid caused by leakage in conventional swivels. Auger rigs can be converted to circulating, rotary drilling rigs.

When drilling with large diameter pipe, this swivel can be mounted below the existing swivel to provide more air or drilling fluid as required. These units are ideal for dual-tube drilling on lost circulation holes. The upper and lower connections can be furnished with pin, box or flange.

Features in Brief

- Compact design for use on short mast rigs.
- Sealed bearings give ample load capacity.
- Adjustable Chevron V-Type packing easily replaceable.

Weight and Dimensional Data

Length Inches	Width	Weight	Connections*	Watercourse Diameter	Hose Connection
22 3/4"	8 5/16"	230 lbs.	3 1/2 API Reg. RH	1 1/2"	2"

*Consult factory for other connections.

Parts List for Type 4.5 Side Inlet Swivel

Part Number	Name of Part	Number Required	Weight lbs.	Spares for One Year
N4.5SI01	Spindle Stem	1	110	
N4.5SI03	Lower Adjusting Gland	1	4	
N4.5SI03A	Lower Adjusting Gland Ring	1	1	2
N4.5SI04	Packoff Housing	2	45	
N4.5SI05416	Packing Set	2	1/2	8
N4.5SI05A	Lantern Ring	1	1/2	4
N4.5SI06	Upper Adjusting Nut	1	4	
N4.5SI07	Lower Grease Seal	1	1	2
N4.5SI09	Bearing Housing	1	20	
N4.5SI10	Upper Housing Seal	1	1	1
N4.5SI11	Bearing Housing Cap	1	5	
N10XV11	Bearing Retainer Wire	1		1
N4.5SI26	Bearing	2	10	2
N4.5SI33A	Bearing Spacer	1	1	1